

/ Data Sheet

Air Jet Dust Collector - Model TBLM



Product Features and Structure:

- Primary de-dust equipment in grain processing industry
- Modular design for a variety of series and models (low pressure, high pressure, ordinary, flip top)
- Updated design of air tank with leaking free
- Solenoid valve controlled compressed air blowback bag cleaning
- Innovated design of air blowback nozzle for air dynamic characteristics (Patent: ZL200920091844.6) for less restriction, high air flow speed and efficient outcome
- Programmable timer control for setting up pulse frequency and blowing time
- Flip top design enable quick maintenance and service
- Optional full funnel bottom cone for easy dust collection
- Optional supply with anti static or water proof cleaning bags
- Laser cutting applies to sheet metal components for quality and accuracy
- Carbon dioxide gas shielded welding workmanship
- CNC machining centres ensure precise fabrication
- Powder coated parts and components for best quality and duration

Technical Parameter

Spec. Model	Sleeve Length (mm)	Air Volume (m3/h)	Filtrating area (m2)	Air Lock motor Power (kW)	Cleaning Board Motor Power (kW)	Low Pressure Pump Model	Weight - A B C (kg)
TBLM-26	1800	1032-5160	17.2	0.75			710 573 672
	2000	1146-5730	19.1				749 663 705
	2400	1380-6900	23				794 920 730
TBLM-39	1800	1542-7710	25.7			ZYMB40	1030 823 781
	2000	1722-8610	28.7				1080 860 1025
	2400	2076-10380	34.6				1120 915 1072
TBLM-52	1800	2112-10560	35.2			ZYMB40	1230 998 1169
	2000	2292-11460	38.2				1500 1030 1218
	2400	2766-13830	46.1				1700 1124 1286
TBLM-78	1800	3090-15450	51.5	1.1	1.5	ZYMB60	1720 1387 1634
	2000	3538-17190	57.3				1800 1453 1721
	2400	4146-20730	69.1				2000 1552 1798
TBLM-104	1800	4116-20580	68.6			ZYMB80	2200 1640 2000
	2000	4590-22950	76.5				2500 1910 2320
	2400	5526-27630	92.1				3000 2220 2650
TBLM-130	1800	5292-26460	88.2			ZYMB140	2870 2132 2610
	2000	5934-29670	98.9				3000 2233 2735
	2400	7056-35280	117.6				3500 2384 2860
TBLM-168	1800	6836-34170	113.9	1.5 x 2	2.2		3540 2652 3225
	2000	7596-37980	126.6				3721 2793 3377
	2400	9114-45570	151.9				3925 2994 3547

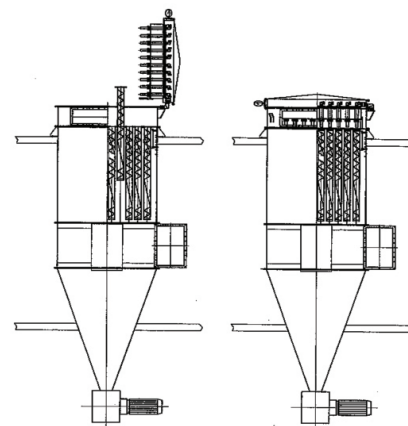

Ashley Fraser

Seed & Grain Equipment World

PO Box 76, Rutherglen, Victoria 3685, Australia.

Phone +61 (0)418 176 764

Fax +61 (0)2 6032 9043

email: ash@sageworld.com.au

Call us today

PH. 61 (0)418 176 764



www.sageworld.com.au